

APPROVED	CHECKED	DESIGNED	DRAWING	SCALE	DRAWING NO.	WEIGHT
			K. Ashizawa 2005. 09. 20	1/10		ab. 270 kg

万能調理器

UNIVERSAL COOKING MACHINE

SS-30

SPECIFICATION		No.	ARTICLES	名称	MATERIAL	Q'TY	REMARKS
CAPACITY	30 Liter	1	GEAR BOX	ギヤーボックス	Fc200	1set	
WATTAGE	0.75 KW	2	CONNECTION OF ATTACHMENT	アタッチメント接続部	Fc200	1	
VOLTAGE	440 VAC	3	COLUMN	支柱	Fc200	1	
PHASE	3 φ	4	COVER OF VOLT	ベルトカバー	Fc200	1	
CYCLE	60 Hz	5	MOTOR	モーター		1	
		6	HOOK ARM	フックアーム	Fc200	1	
FINISHED WITH MUNSELL	2.5G 7/2	7	BOWL	ボウル	SUS304	1	
		8	CABLE GLAND	ケーブルグランド	Bc	1	20b
		9	CRATCH LEVER 1	クラッチレバー 1	Fc200	1	Low, Mid.
		10	CRATCH LEVER 2	クラッチレバー 2	Fc200	1	Hi., Top
		11	BOWL SUPPOTER	ボウル受け	Fc200	1set	
		12	HANDLE FOR BOWL SLID	ボウル昇降ハンドル	Fc200	1	
		13	LEVER FOR BOWL DETAIN	ボウル固定レバー	Fc200	2	
		14	CAP (GEAR BOX OIL)	オイル投入口キャップ		1	
		15	BASE	ベース	Fc200	1	

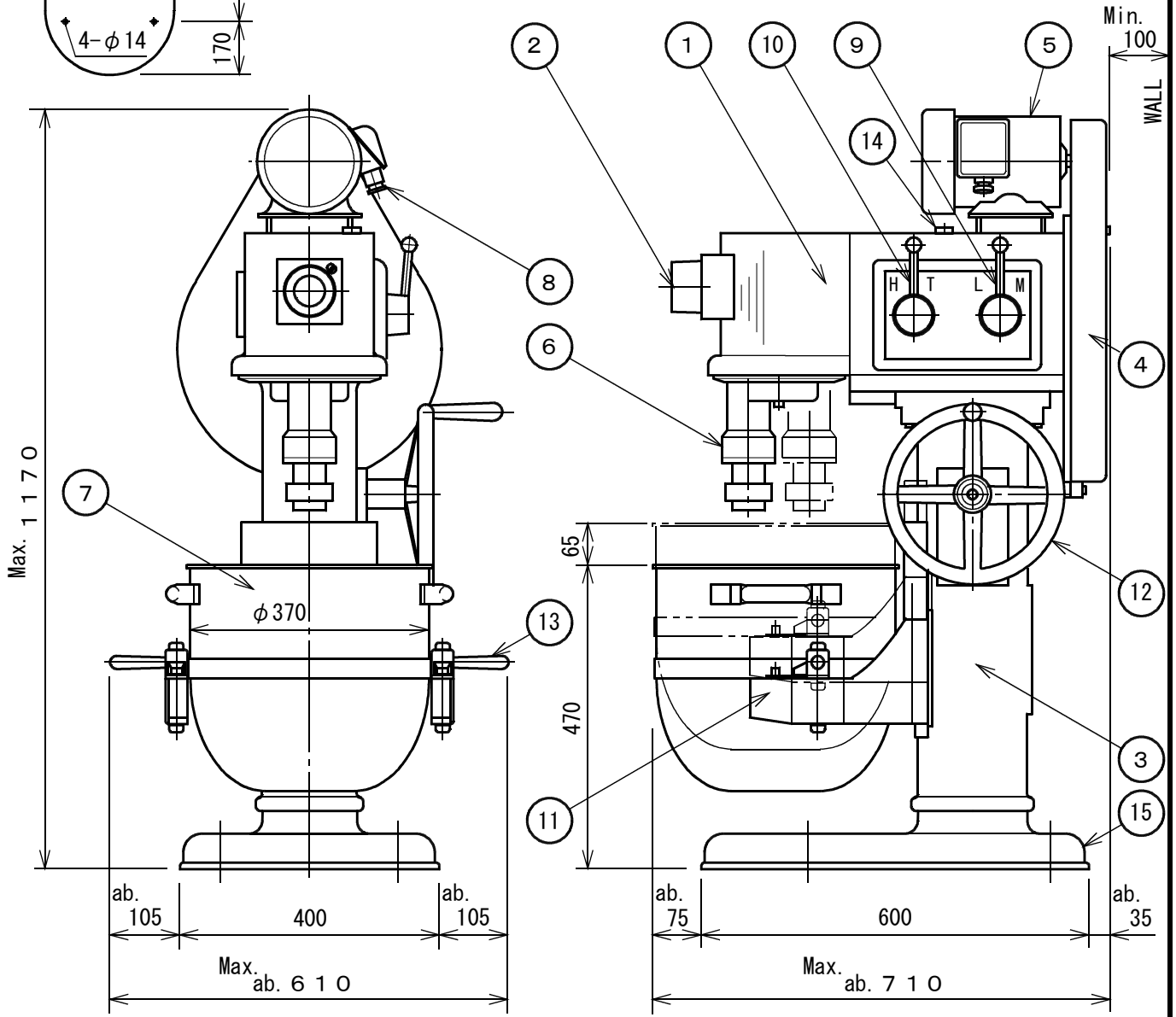
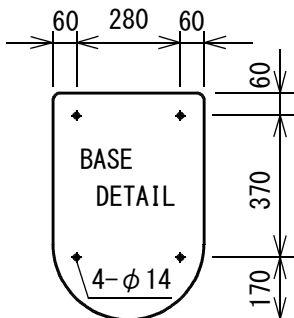

APPROVED	SHECKED	DESIGNED	DRAWING	SCALE	DRAWING NO.	WEIGHT
			K. Ashizawa 2005.04.11	1/5		kg

万能調理器 起動器
STARTER FOR UNIVERSAL COOKING MACHINE SS-30

SYMBOL	ARTICLES	名称	TYPE	Q'TY	REMARKS
WL	SOURCE LAMP	電源表示灯	ILT-200W	1	MARUYASU
GL	RUNNING LAMP	運転表示灯	ILT-200G	1	MARUYASU
PB1	START PUSH BUTTON	起動押釦	PF-10G	1	MARUYASU
PB2	STOP PUSH BUTTON	停止押釦	PT-01R	1	MARUYASU

MATERIAL : SUS 430

材質

BODY : POLISHED

本体 : パフ仕上げ

WITH EARTH TERMINAL

アース端子付

