

APPROVED	CHECKED	DESIGNED	DRAWING	SCALE	DRAWING NO.	WEIGHT
				1/10		160kg

UNIVERSAL COOKING MACHINE

SS-20

SPECIFICATION	No.	ARTICLES	名 称	MATERIAL	QUAN	REMARKS
CAPACITY 20 ^l	1	BACK GEAR BOX	後部ギヤボックス	Fc200	1	
WATTAGE 0.4 kw	2	FRONT GEAR BOX	前部ギヤボックス	Fc200	1	
VOLTAGE AC 440 V	3	COLUMN	支 柱	Fc200	1	
PHASE 3 ϕ	4	BELT COVER	ベルトカバー	Fc200	1	
CYCLE 60 Hz	5	MOTOR	モーター		1	SF-4KW SF-JR
	6	AGITATOR COVER	攪拌機カバー	Fc200	1	
FINISHED WITH MUNSELL 7.5BG7/2	7	BOWL	ボール	SUS304	1	
	8	CABLE GLAND	ケーブルグランド	Bc	1	20b
	9	SPEED CHANGE HANDLE	クラッチハンドル	SS400	2	
	10	SLIDING HANDLE	ボール用ハンドル	Fc200	1	
	11	BOWL SUPPORTER	ボール支持	Fc200	1set	
	12	BASE	ベース	Fc200	1	

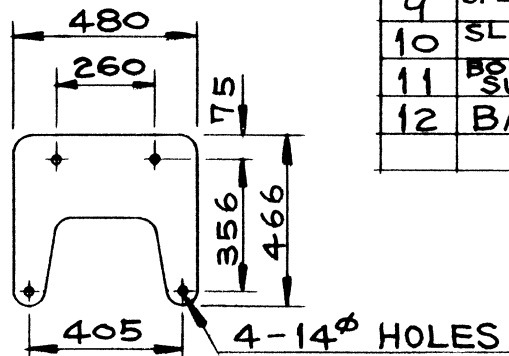

BASE DETAIL

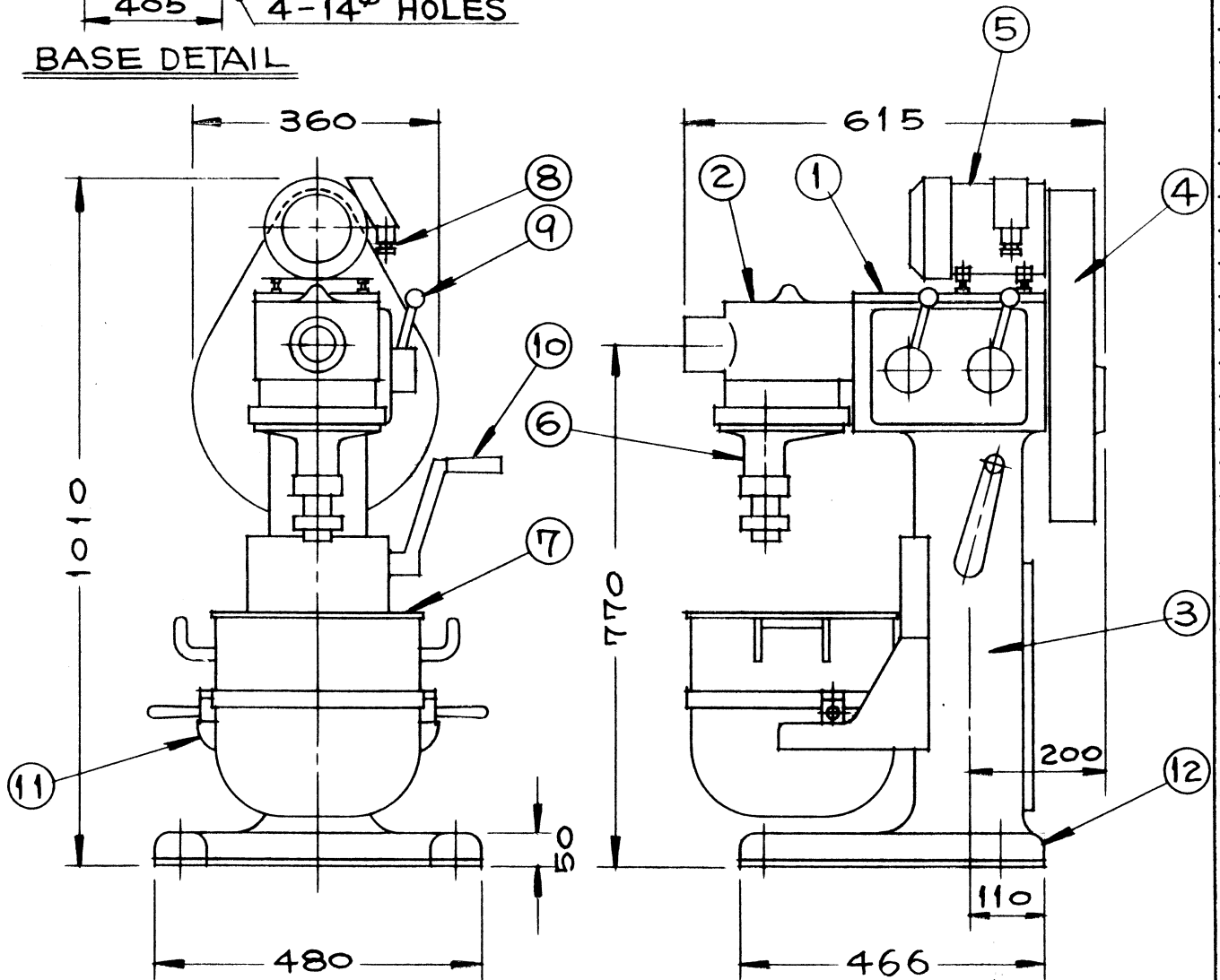

APPROVED	SHECKED	DESIGNED	DRAWING	SCALE	DRAWING NO.	WEIGHT
			K. Ashizawa 2005.04.11	1/5		kg

万能調理器 起動器
STARTER FOR UNIVERSAL COOKING MACHINE SS-20

SYMBOL	ARTICLES	名称	TYPE	Q'TY	REMARKS
WL	SOURCE LAMP	電源表示灯	ILT-200W	1	MARUYASU
GL	RUNNING LAMP	運転表示灯	ILT-200G	1	MARUYASU
PB1	START PUSH BUTTON	起動押釦	PF-10G	1	MARUYASU
PB2	STOP PUSH BUTTON	停止押釦	PT-01R	1	MARUYASU

MATERIAL : SUS 430

材質

BODY : POLISHED

本体 : パフ仕上げ

WITH EARTH TERMINAL

アース端子付

