

No.	ARTICLES	名称	MATERIAL	Q'TY	REMARKS
1	BODY	本体		1	
2	GRINDING DEVICE	研磨装置		1	
3	INSTALLATION KNOB of ROUND EDGE COVER	丸刃カバー取付ノブ	RESIN	1	
4	ROUND EDGE	丸刃	SUS	1	φ220mm
5	ROUND EDGE COVER	丸刃カバー		1	
6	FOOT	脚	RUBBER	4	
7	PUSHING BOARD	送り込み押し板		1	
8	HANDLE	ハンドル	RESIN	1	
9	SLIDING BED	スライドテーブル		1	
10	INSTALLATION KNOB of ARM	アーム取付ノブ	RESIN	1	
11	ADJUSTMENT BOARD of THICK	厚み調整板		1	
12	ADJUSTMENT DIAL of THICK	厚み調整ダイヤル	RESIN	1	0.1~18mm
13	SWITCH	スイッチ		1	
14	MOTOR	モーター		1	250W
15	CORD	コード		1.5m	

PLUG : \_\_\_\_\_

SPECIFICATION	
WATTAGE	250W
VOLTAGE	100VAC / 220VAC
PHASE	1φ
CYCLE	50/60Hz
SLICE CAPACITY	ab.1000 slice/h
THICK of SLICE	0.1~18mm
SLICE SIZE	90×170(φ120)mm

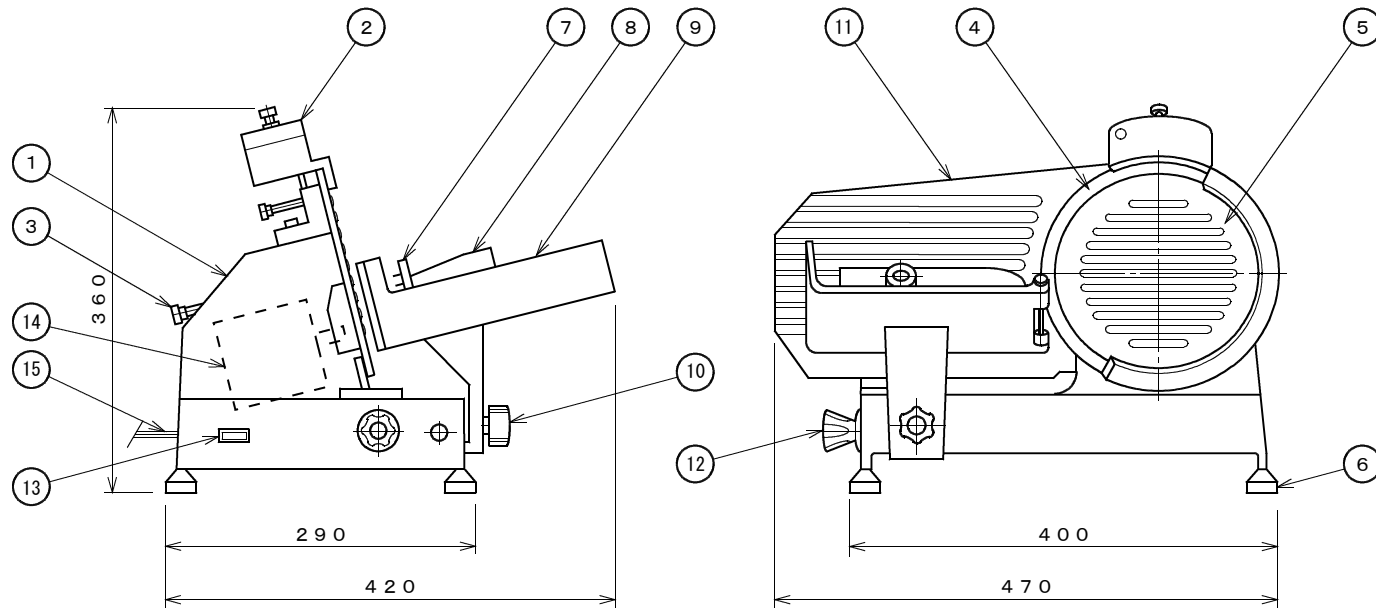

APPROVED BY	CHECKED BY	DESIGNED BY	DRAWN BY	SCALE	WEIGHT
			K. Ashizawa 2007.01.16	1/5(A-3)	ab. 15 Kg
SANWA CHŪRI INDUSTRY CO., LTD.				DRAWING NO.	

HAM & MEAT SLICER  
 ハム・ミート スライサー  
 OMS-220