

APPROVED	SHECKED	DESIGNED	DRAWING	SCALE	DRAWING NO.	WEIGHT
			K. Ashizawa 2009. 12. 09	1/10		ab. 86 Kg

DISPOSER

ディスポーザー

SD-22H

SPECIFICATION 仕様		
DISPOSING CAPACITY	容量	15Kg/min.
WATTAGE	電気容量	2.2KW
VOLTAGE	電圧	440V
PHASE	相数	3φ
CYCLE	周波数	60Hz
CONSUMPTION OF WATER	水量	14 L/min.
FINISHED WITH MUNSELL	塗装色	7.5BG7/2

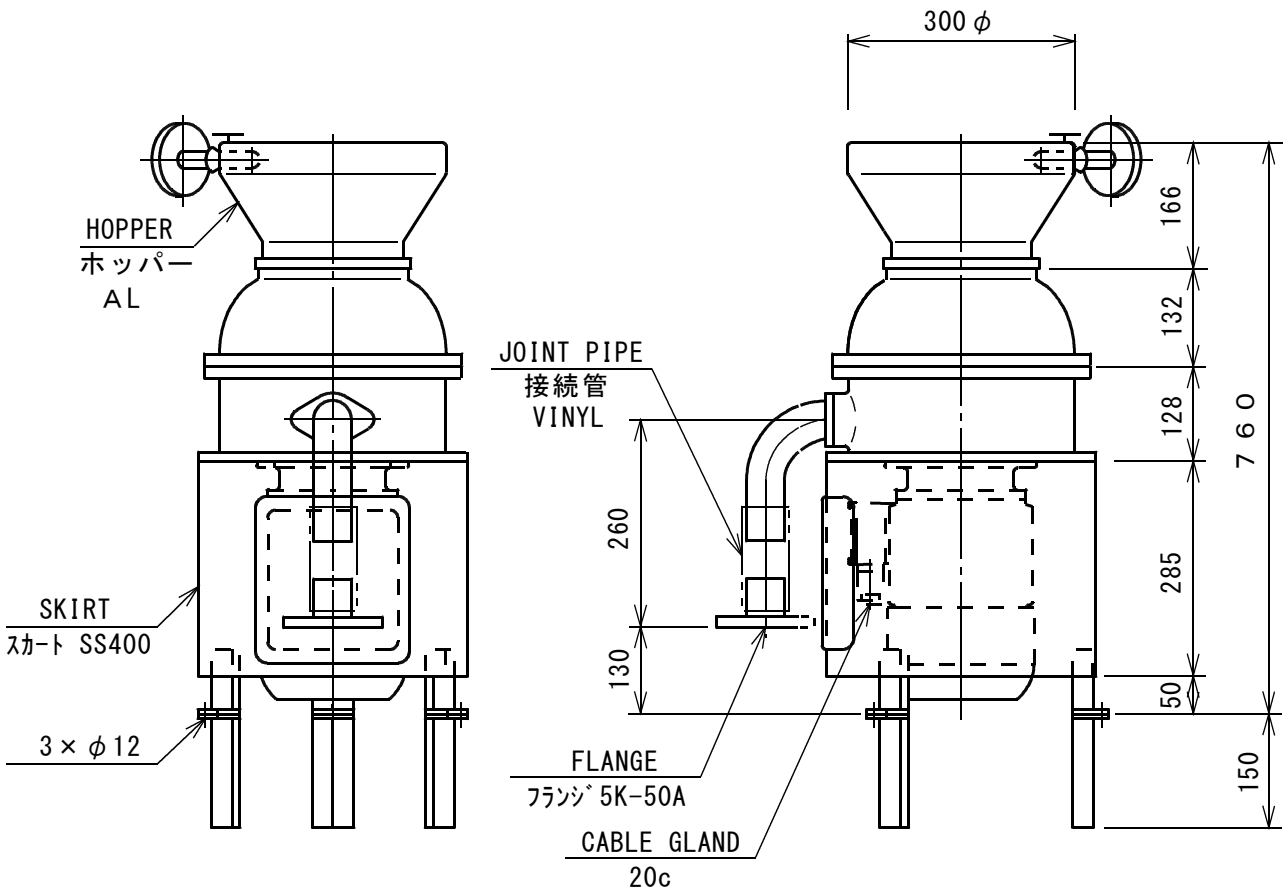
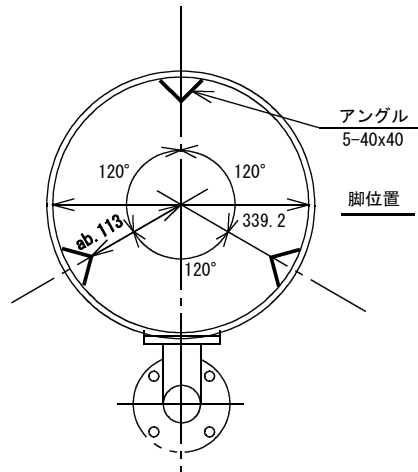
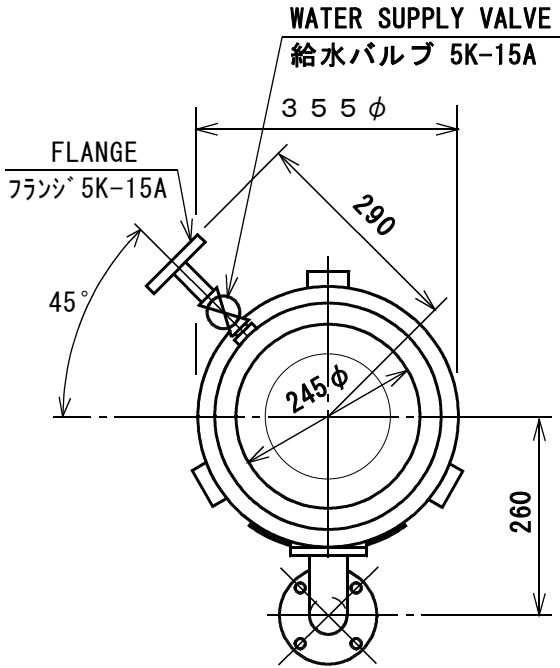

APPROVED	SHECKED	DESIGNED	DRAWING	SCALE	DRAWING NO.	WEIGHT
			K. Ashizawa 2004.03.16	1/5		kg

ディスポーザー 起動器 STARTER FOR DISPOSER SD-22H

SYMBOL	ARTICLES	名称	TYPE	Q'TY	REMARKS
WL	SOURCE LAMP	電源表示灯	ILT-200W	1	MARUYASU
GL	RUNNING LAMP	運転表示灯	ILT-200G	1	MARUYASU
PB1	START PUSH BUTTON	起動押釦	PF-10G	1	MARUYASU
PB2	STOP PUSH BUTTON	停止押釦	PT-01R	1	MARUYASU

MATERIAL : SUS430
材 質

BODY : POLISHED
本 体 : パフ仕上げ

WITH EARTH TERMINAL
アース端子付

