

APPROVED	SHECKED	DESIGNED	DRAWING	SCALE	DRAWING NO.	WEIGHT
			K.Ashizawa 2004.12.08	1/8		ab. 11kg

電気湯沸器

ELECTRIC WATER BOILER

NEWK-20

SPECIFICATION	
CAPACITY	20 L
WATTAGE	2.0 KW
VOLTAGE	100 VAC
PHASE	1
CYCLE	50/60Hz

BODY : POLISHED
本体 : パフ仕上げ

No.	ARTICLES	名称	MATERIAL	Q'TY	REMARKS
1	BODY	本体	NAR315SN	1	1.0t
2	LID	蓋	NAR315SN	1	1.0t
3	THERMOSTAT	サーモスタット		1	EA3-L
4	FLOAT VALVE	フロート弁		1	PF1/2"
5	LEVEL GAUGE	湯面計	Bc2, GLASS	1	10-200L
6	THERMO-METER	温度計		1	0~100
7	FAUCET	蛇口	Bc2	1	Ni PL.
8	HEATER	ヒーター	CuT, Ni PL.	2	1.0KW
9	RUNNING LAMP	運転表示灯		1	LMU-6MS
10	CABLE GLAND	ケーブルグランド	Bc2	1	20c
11	CABTYRE CORD	キャブタイヤコード	TPNP-4	1	1.5m
12	DRAIN VALVE	ドレンバルブ		1	1/2" (15A)
13	DRAIN	ドレン	SUS304	1	1/2" (15A)

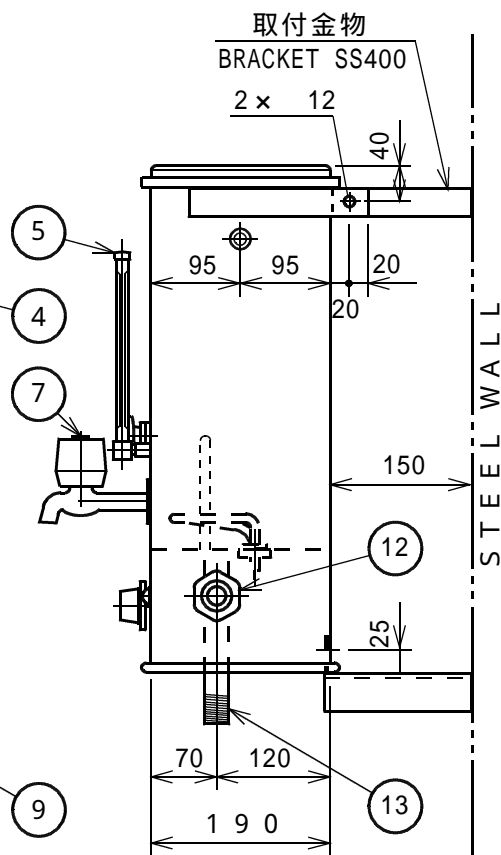
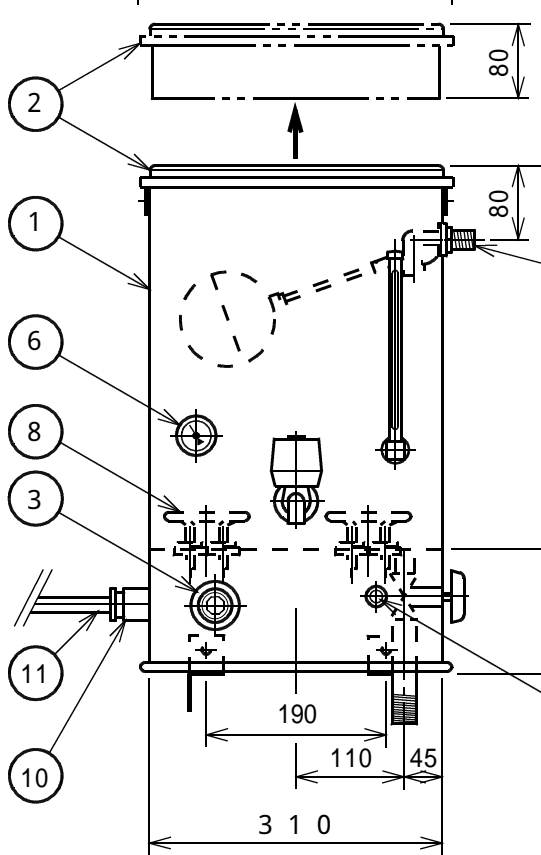
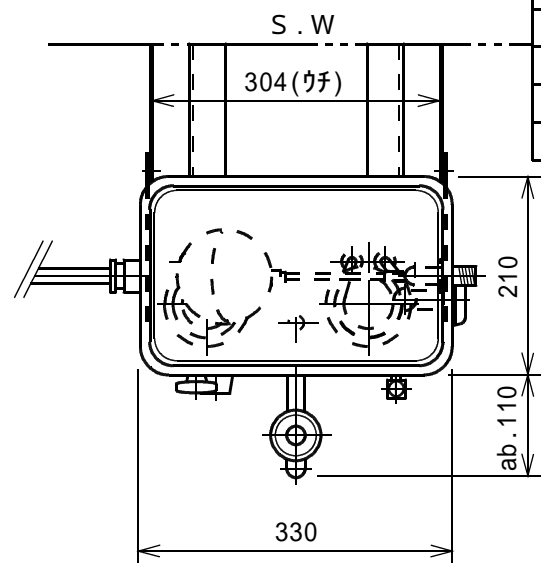

取付金物
BRACKET SS400
2 x 12

STEEL WALL