

SPECIFICATION		No.	ARTICLES	名称	MATERIAL	Q'TY	REMARKS
GRILL	10.0KW	1	BODY	本体	SUS430	1set	
HOT PLATE	4.0KW×2	2	TOP PLATE	頂板	SUS430	1set	
OVEN	5.0KW	3	GRILL HEATER	魚焼きヒーター	SUS304	12	830W
TOTAL WATTAGE	23.0KW	4	DRIP PAN	汁受け皿	SUS430	3	
VOLTAGE	440VAC	5	HOT PLATE	ホットプレート		2	4000W
PHASE	3φ	6	ROLLING BAR	ローリングバー	SUS430	1set	
CYCLE	60Hz	7	OVEN	焼オープン	SUS430	1	
BODY	POLISHED	8	OVEN HEATER	オープンヒーター	SUS304	6	830W
OVEN SIZE		9	INSULATION	断熱材	ROCKWOOL	1set	25t
515W×470D×360H		10	OVEN EXHAUST	オープン排気口		1	
WITH EARTH TERMINAL		11	HAND RAIL	手摺	SUS304	1	20A
		12	CABLE GLAND	ケーブルグランド	BC	1	25b
		13	LEG	脚	SUS430	4	
		14	FOOT PIECE	取付脚		4	

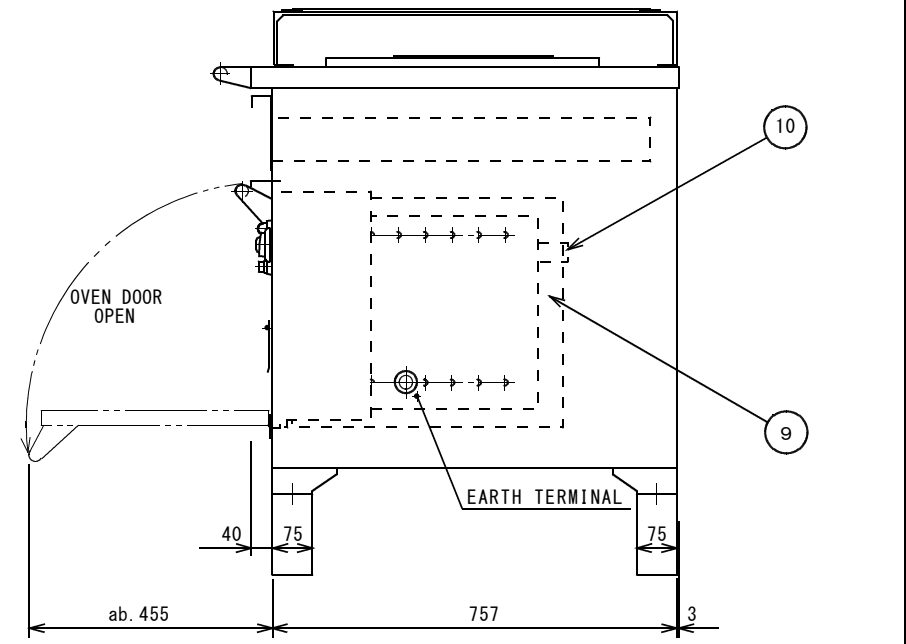
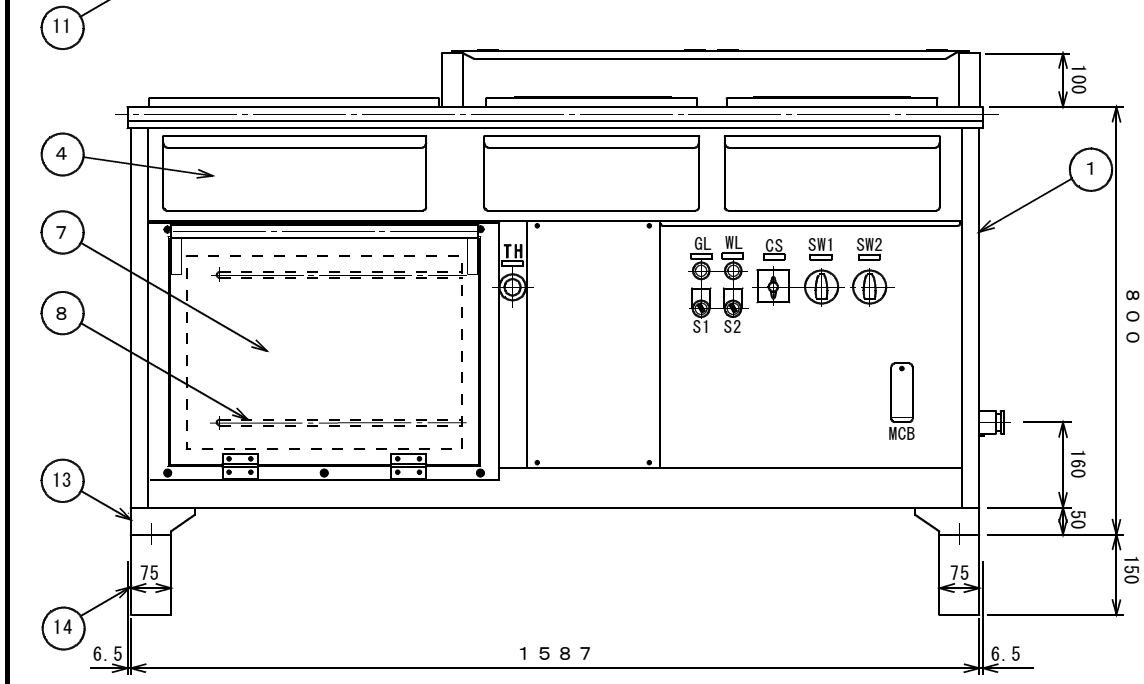

APPROVED BY	CHECKED BY	DESIGNED BY	DRAWN BY	SCALE	WEIGHT	ELECTRIC COOKING RANGE 電気レンジ
			K. Ashizawa 2009. 10. 14	1/10	ab. 210 Kg	
SANWA CHŪRI INDUSTRY CO., LTD.				DRAWING NO. G501551		ROH44GD-4