

SPECIFICATION	
OVEN	5.0KW
FERMENTATION	1.0KW
TOTAL WATTAGE	6.0KW
VOLTAGE	440VAC
PHASE	3φ
CYCLE	60Hz
BODY	POLISHED
OVEN SIZE	850W × 550D × 300H

No.	ARTICLES	名称	MATERIAL	Q'TY	REMARKS
1	BODY	本体	SUS430	1set	
2	TOP PLATE	頂板	SUS430	1set	
3	FRONT PLATE	前板	SUS430	1	
4	OVEN	オーブン	SUS430	1	
5	OVEN HEATER	オーブンヒーター	SUS304	6	830W
6	INSULATION	断熱材	ROCKWOOL	1set	25t
7	DAMPER KNOB	ダンパーつまみ	BAKELITE	1	
8	FERMEN. BOX	発酵室	SUS430	1	
9	FERMEN. HEATER	発酵室ヒーター	SUS304	1	500W
10	CABLE GLAND	ケーブルグランド	BC	1	20c
11	SOURCE LAMP	電源表示灯		1	
12	RUNNING LAMP	オーブン運転表示灯		1	
13	THERMOSTAT	サーモスタット		1	
14	OVEN SWITCH	オーブンスイッチ		2	
15	RUNNING LAMP	発酵運転表示灯		1	
16	FERMEN. SWITCH	発酵室スイッチ		1	
17	LEG	脚	SS400	4	
18	FOOT PIECE	取付脚		4	

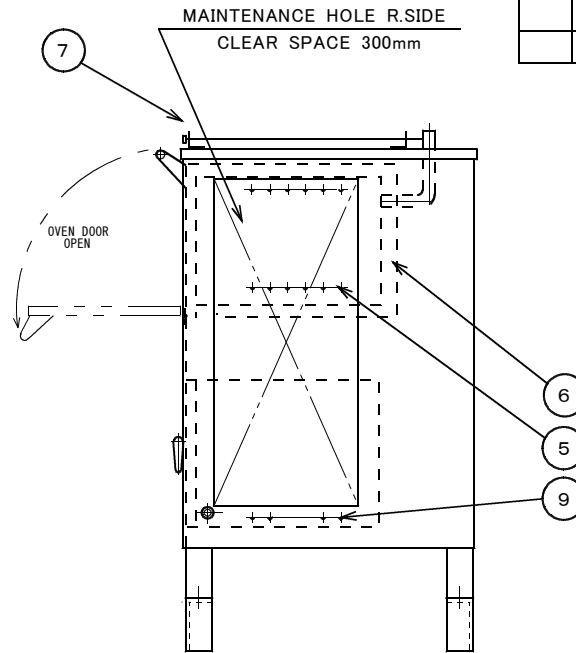
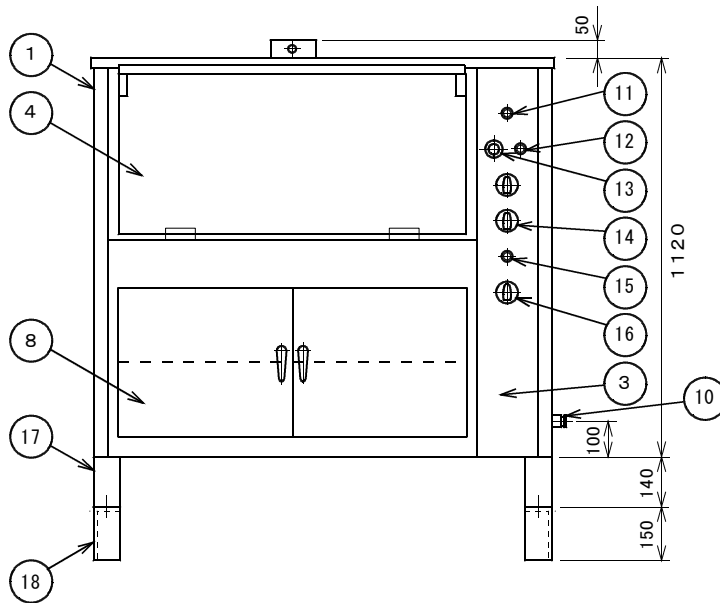

APPROVED BY	CHECKED BY	DESIGNED BY	DRAWN BY	SCALE	WEIGHT
			K. Ashizawa 2008. 11. 18	1/15	ab. 280 Kg
SANWA CHURI INDUSTRY CO.,LTD.				DRAWING NO.	

ELECTRIC BAKING OVEN  
電気ベーキングオーブン  
EB-6P